

## 螺纹铣刀杆 – 单刃型 Single insert toolholders

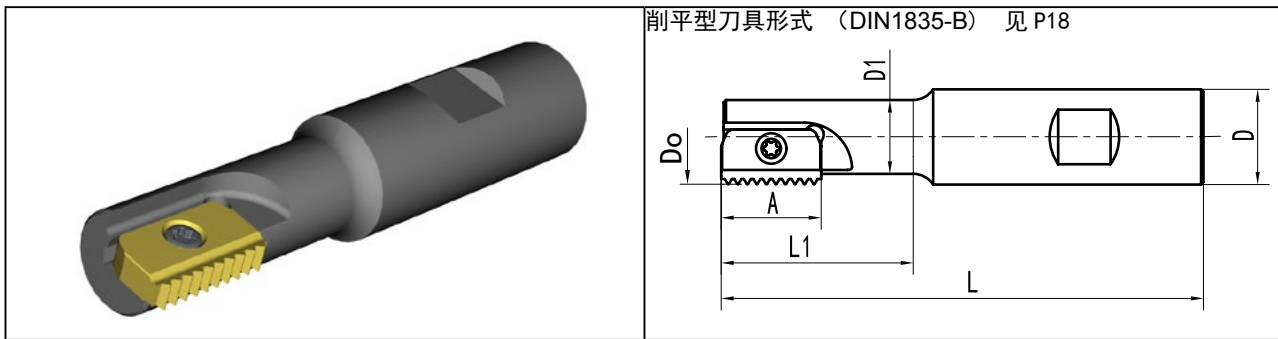

刀杆型号 Toolholder Type	刀片型号 Insert Type	尺寸 Dimensions (mm)						刀片螺钉 Insert Screw	扳手 Torx Key
		Do	L1	D	D1	L	A		
SR0010H12	12N**	9.5	20	16	7.6	85	12	L60M2.5x6	T-8
SR0012F14	14N/E**	12	23	20	8.9	80	14	L60M3*6.5	T-8
SR0014H14		14.5	26	20	11.2	85	14	L60M3*8	T-10
SR0017H14		17	35	20	13.4	85	14	L60M3*8	T-10
SR0018H21	21N/E**	18	35	20	13.8	85	21	L60M3.5*8	T-15
SR0021H21		21	44	20	15.5	94	21	L60M3.5*10	T-15
SR0029J30	30N/E**	29	52	25	22	110	30	L60M4*0.5*11.5	T-15
SR0048M40	40N/E**	48	83	40	35	153	40	L60M5*0.8*14	T-20

\*SR0018H21 cannot be used for : 21N/E3.5ISO, 21N/E7UN, 21N/E8UN, 21-11BSPT, 21-11.5NPT

Available for inner hole cooling holders, add "-OH", example : SR0017H14-OH

加长螺纹铣刀杆 - 单刃型 Single insert toolholders-extra lengthen

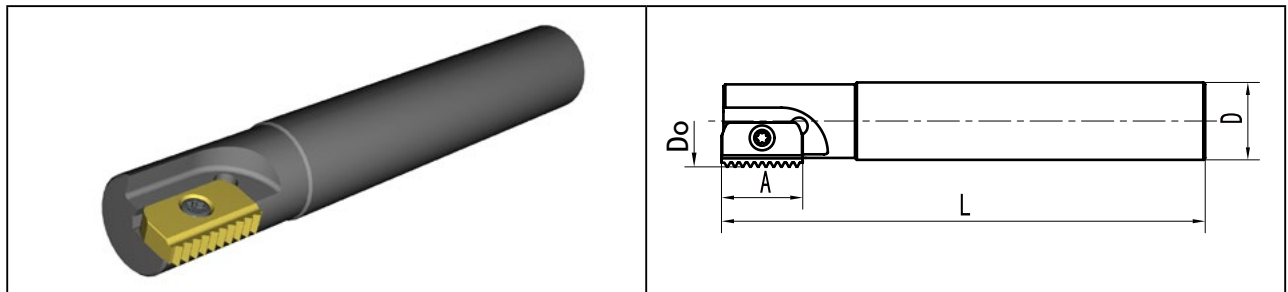

刀杆型号 Toolholder Type	刀片型号 Insert Type	尺寸 Dimensions (mm)				刀片螺钉 Insert Screw	扳手 Torx Key
		Do	D	L	A		
SR0025K21	21N/E**	25	20	125	21	L60M3.5x10	T-15
SR0031M30	30N/E**	31	25	150	30	L60M4*0.5*11.5	T-15
SR0038M30		38	32	150	30	L60M4*0.5*11.5	T-15
SR0038Q40	40N/E**	38	32	180	40	L60M5*0.8*14	T-20
SR0048R40		48	40	210	40	L60M5*0.8*14	T-20

Available for inner hole cooling holders, add "-OH", example : SR0025K21-OH

螺纹铣刀杆 - 硬质合金抗震型 Carbide anti-seismic style

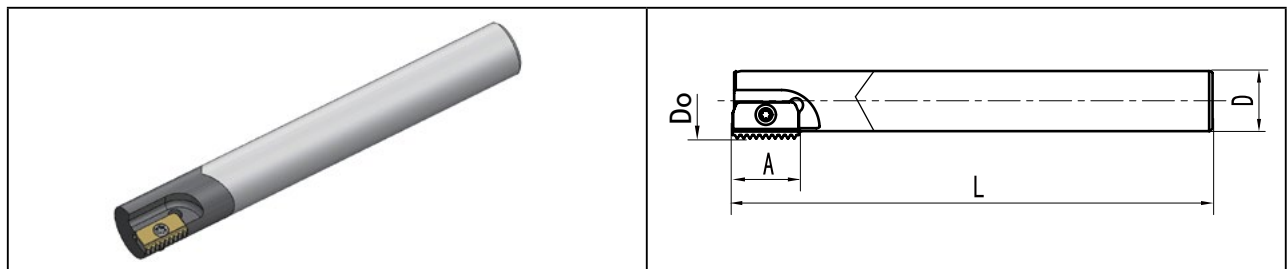

刀杆型号 Toolholder Type	刀片型号 Insert Type	尺寸 Dimensions (mm)				刀片螺钉 Insert Screw	扳手 Torx Key
		Do	D	L	A		
SR0010K12-WH	12N**	9.9	8	125	12	L60M2.5x6	T-8
SR0013J14-WH	14N**	13.2	10	110	14	L60M3*6.5	T-10
SR0013M14-WH		13.2	10	150	14	L60M3*6.5	T-10
SR0015P14-WH		15.2	12	175	14	L60M3*8	T-10
SR0021R21-WH	21N**	21.0	16	200	21	L60M3.5*10	T-15
SR0027Q30-WH	30N/E**	27.0	20	180	30	L60M4*0.5*11.5	T-15
SR0027S30-WH		27.0	20	270	30	L60M4*0.5*11.5	T-15

## 螺纹铣刀杆 – 双刃型 Twin insert toolholders

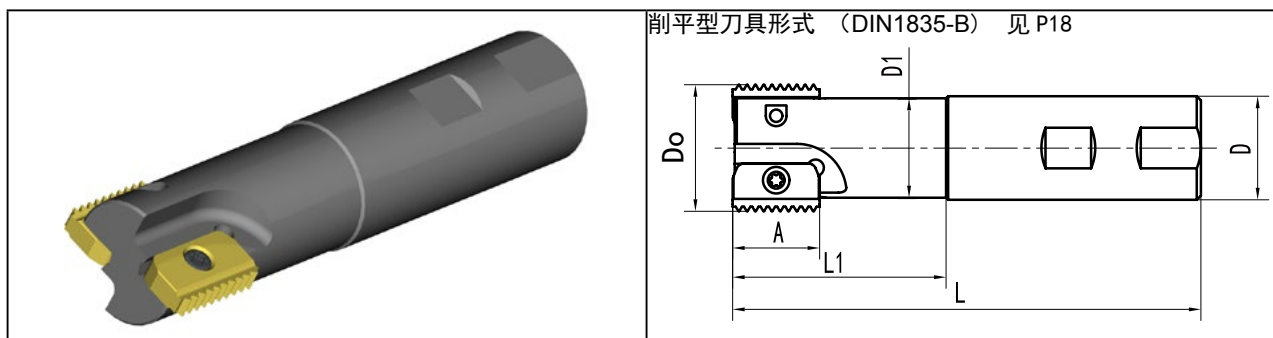

刀杆型号 Toolholder Type	刀片型号 Insert Type	刃数 No. ofinse	尺寸 Dimensions (mm)						刀片螺钉 Insert Screw	扳手 Torx Key
			Do	L1	D	D1	L	A		
SR0020G14-2	14N/E**	2	20	37	20	16	93	14	L60M3x7	T-10
SR0020J14-2		2	20	57	20	16	113	14	L60M3*7	T-10
SR0030J21-2	21N/E**	2	30	52	25	24	113	21	L60M3.5*10	T-15
SR0030L21-2		2	30	80	25	24	140	21	L60M3.5*10	T-15
SR0040L30-2	30N/E**	2	40	70	32	30	135	30	L60M4*0.5*11.5	T-15
SR0040P30-2		2	40	103	32	30	170	30	L60M4*0.5*11.5	T-15
SR0050M40-2	40N/E**	2	50	80	40	38	153	40	L60M5*0.8*14	T-20

Available for inner hole cooling holders, add "-OH", example :SR0030L21-2-OH

## 螺纹铣刀盘 Threading milling toolholders

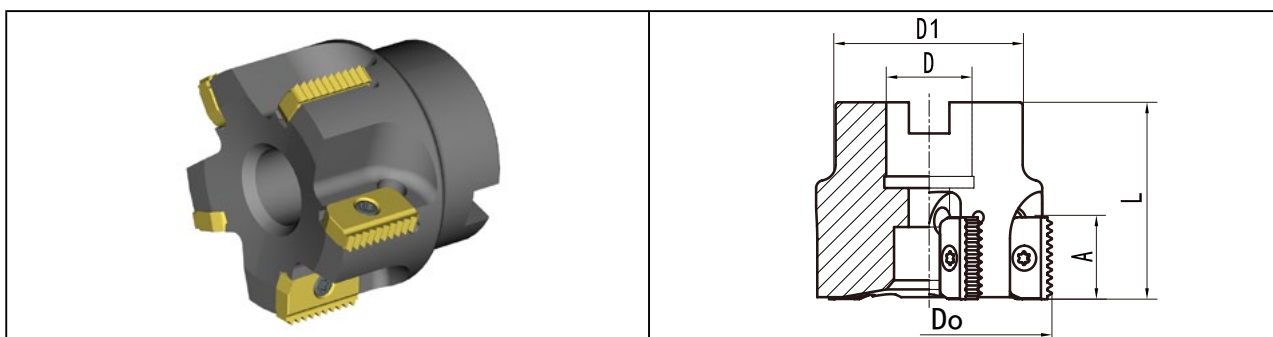

刀杆型号 Toolholder Type	刀片型号 Insert Type	刃数 No. ofinse	尺寸 Dimensions (mm)					刀片螺钉 Insert Screw	扳手 Torx Key
			Do	D	D1	L	A		
SR0063C21-5	21N/E**	5	63	22	48	50	21	L60M3.5x10	T-15
SR0063C30-4	30N/E**	4	63	22	48	50	30	L60M4*0.5*11.5	T-15
SR0080D30-4		4	80	27	60	55	30	L60M4*0.5*11.5	T-15
SR0100D30-4		4	100	32	78	60	30	L60M4*0.5*11.5	T-15
SR0080D40-4	40N/E**	4	80	27	60	65	40	L60M5*0.8*14	T-20
SR0100E40-4		4	100	32	78	70	40	L60M5*0.8*14	T-20

Available for inner hole cooling holders, add "-OH", example :SR0063C21-5-OH